

Single Effect Vacuum Evaporators

Mech-Chem's single effect vacuum evaporators use conventional climbing film evaporative principles with a horizontal tube arrangement.

The vacuum evaporator is designed to produce a high purity distillate while maximizing volume reduction of the waste, wastewater or waste acid solution being processed.

Mech-Chem fabricates each vacuum evaporator using the appropriate materials of construction for the specified application (i.e. wastewater, salt solution or acid solution). This provides maximum corrosion resistance with a long service life and low maintenance.

The vacuum evaporators are also equipped with NEMA 4x electrical components and PLC Controller. This provides an automated evaporation system that is reliable and easy to operate.



Wastewater and Rinse Water

- Removal and recovery of heavy metals
- Meet stringent or non-detectable metal limits
- Meet non-detectable mercury limits
- Meet new molybdenum limits
- Used with UF/RO or Ion Exchange to create "Zero Discharge Systems"

Acid Recovery and Recycling

- Recover 85%-90% of acids
- Eliminate off-site disposal of waste acid solutions
- Reduce raw material costs
- Eliminate shipping of hazardous chemicals
- Eliminate "cradle to grave" liability

Metals Concentration and Recovery

- Chemical milling solutions
- Acid etching solutions
- Metal dissolving acid solutions
- Concentration of plating solutions
- Recycling of plating bath metals
- Concentration of dilute acid solutions





Vacuum evaporation system for the recovery of nitric acid, sulfuric acid and molybdenum. Produces 50-60wt% nitric acid. Evaporator fabricated using 304L stainless steel with zirconium tube bundle, NEMA 4X electrical components, and PLC automation with PC interface.

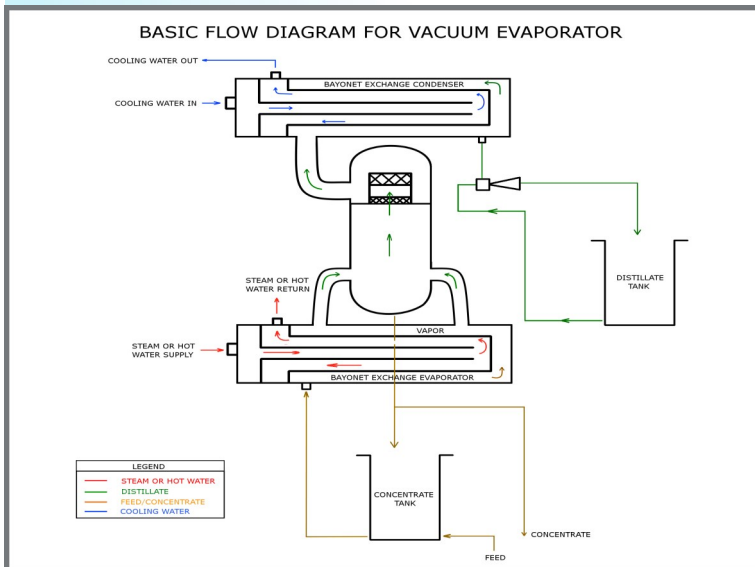

Benefits

- Operates at low temperatures
- Reduce energy costs
- Vacuum system with no air emissions
- Eliminates potential for vapor leaks
- No external vacuum source
- No environmental permitting required
- Maximum waste/wastewater reduction
- Produces high purity acids
- Safe design (meets OSHA requirements)

Verified Results

- Production of clean, distilled water for recycling
- Production of distilled water with non-detectable metals including mercury and molybdenum
- Recovery of mixed acid solutions
- Production of 50-60wt% high purity nitric acid
- Concentration of plating baths for recycling
- Produces high concentration of waste and reusable by-products
- Recovery of metals from concentrate by-products by relaimers.

Versatile Design

- Mech-Chem's evaporators are skid mounted modular units with concentrate and distillate tanks.
- Evaporators are equipped with automatic valves and instrumentation for PLC control
- Conventional design for industries with steam, hot water or virtually any waste heat source (all-electric alternative also available)
- Unique vacuum design which provides a totally closed system.



Telephone: (508) 528-5990 Fax: (508) 528-8972

144 Main Street, P.O. Box 473 Norfolk, Ma 02056
E-mail: inquiry@mech-chem.com Visit: www.mech-chem.com